

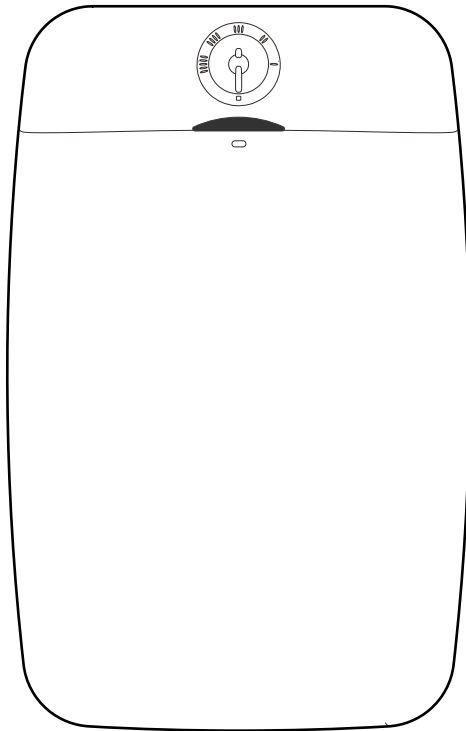

Unvented Electric Water Heater 10/15 litre Undersink



CONTENTS

SECTION	PAGE
1.0 INTRODUCTION	2
2.0 TECHNICAL SPECIFICATION	3
3.0 INSTALLATION	4
4.0 COMMISSIONING	9
5.0 EXPLANATION TO USER	10
6.0 MAINTENANCE	11
7.0 FAULT FINDING	13
8.0 SPARE PARTS	14
9.0 GUARANTEE	15
10.0 ENVIRONMENTAL INFORMATION	15
11.0 WARRANTY & SPARES ENQUIRIES	16

1.0 INTRODUCTION

Thankyou for purchasing our 10/15 litre unvented water heater. The water heater has been manufactured to the highest standards and has been designed to meet all the latest relevant safety specifications.

1.1 IMPORTANT POINTS

This 10/15 litre unvented water heater must be installed (Section 3.0), commissioned (Section 4.0) and maintained (Section 6.0) by a competent person. Please read and understand these instructions prior to installing your water heater.

Following installation and commissioning, the operation of the heater should be explained to the user (Section 5.0) and these instructions left with them for future reference.

This appliance is not intended for use by persons (including children) with reduced physical, sensory or mental capabilities, or lack of experience and knowledge, unless they have been given supervision or instruction concerning the use of the appliance by a person responsible for their safety. Children should be supervised to ensure that they do not play with the appliance.

1.2 PACK CONTENTS

Water heater, pressure relief valve, electrolytic connectors, wall fixings, fitting instructions and warranty card.

2.0 TECHNICAL SPECIFICATIONS

Electrical rating	220-240V~ 50Hz 2kW.
Temperature range	12 to 72°C
Capacities.....	10 or 15 litres
Weight (empty)	10 litre - 6.5kg
.....	15 litre - 7.5kg
Weight (full)	10 litre - 16.5kg
.....	15 litre - 22.5kg
Maximum working pressure.....	0.6MPa (6 bar)
Pressure Relief Valve	0.6MPa (6 bar)
Ingress protection	IP21

The heater can be used to supply multiple hot water outlets via conventional taps. It is not recommended for supplying a shower.

Individual site demands should be considered when choosing capacity and the number of outlets to be served.

10 litre - 1 to 2 hand basins

15 litre - 2 to 3 basins or 1 kitchen sink + 1 hand basin

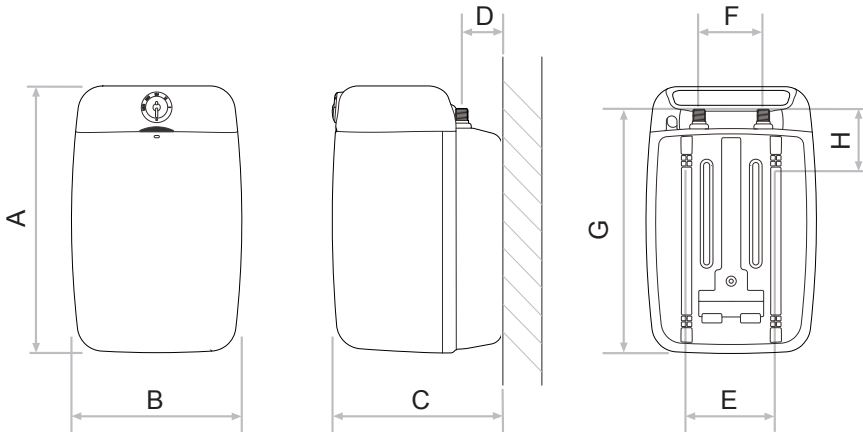

MODEL	A	B	C	D	E	F	G	H
10 litre	415	265	264	73	140	100	380	102
15 litre	445	295	296	93	140	100	420	102

FIG.01: INSTALLATION DIMENSIONS

3.0 INSTALLATION

Warning: this appliance must be earthed. It is suitable for a.c. supply only. Electrical installation must be carried out by a competent electrician and be in accordance with the latest IEE wiring regulation.

3.1 LOCATION

- 3.1.1 National Wiring rules may contain restrictions concerning the installation of these units in bathrooms.
- 3.1.2 The unit should be located in close proximity to its outlet in order to minimise heat losses in the pipework. The unit should be wall-mounted, using the fixing hooks and plugs supplied. The wall fixing hooks should be orientated such that the lugs engage with the mounting slots in the rear of the unit (see Figure 01, page 3 for mounting hole dimensions). The water connections must always be to the top of the unit. Ensure the wall can support the full weight of the unit (see Section 2) and that wall hooks are securely fixed.
- 3.1.3 Enough space should be left above the unit for pipe connections and access to the Pressure Relief Valve (see Figure 01, page 3 for unit dimensions to determine a suitable position for the heater).
- 3.1.4 Ensure that there are no hidden services (electricity, gas or water) below the surface of the wall.
- 3.1.5 DO NOT install where the unit may freeze.

3.2 PLUMBING

- 3.2.1 The water connections are for 15mm diameter copper tubes suitable for compression fittings. Do not use solder joints as this will damage the heater and may prevent servicing.
- 3.2.2 The electrolytic connectors supplied are fitted between the inlet/outlet threaded pipe ends and the 15mm compression fittings attached to the supply/outlet pipework to prevent galvanic corrosion.
- 3.2.3 The INLET is marked BLUE, the OUTLET is marked RED. A WRAS listed isolating valve (not supplied) should be fitted on the cold water supply to the heater. Several hot outlets can be served.
- 3.2.4 Plumbers Paste must not be used as it can impair the operation of the valves.

3.3 IMPORTANT INSTALLATION POINTS

3.3.1 This unvented water heater MUST be fitted with the Pressure Relief Valve supplied. FAILURE TO PROVIDE ADEQUATE PRESSURE RELIEF WILL INVALIDATE ANY GUARANTEE AND LEAD TO A DANGEROUS INSTALLATION.

3.3.2 Expansion can take place within the cold water supply PROVIDED THAT BOTH :

(a) Backflow in the main is not prevented by any stop valve with loose jumper, check valve, pressure reducing valve or similar AND

(b) Hot water expansion does not enter a branch to a cold water outlet (see Figure 02, page 6 for expansion pipe lengths).

N.b. Both the above conditions must be met. Additionally expansion within the cold water supply will not be possible if the static supply pressure exceeds 0.41 MPa (4.1bar).

3.3.3 If any of the conditions in 3.3.2 cannot be met, expansion must be accommodated using an Expansion Vessel. To ensure all expansion takes place in the vessel, a check valve must also be fitted together with the Pressure Relief Valve supplied (see Figure 03, page 6).

3.3.4 If the static supply pressure exceeds 0.41 MPa (4.1 bar), a Pressure Reducing Valve must be fitted to the cold main supply. If a Pressure Reducing Valve is used, an Expansion Vessel must also be used (see Figure 04, page 6).

3.3.5 The installation must be carried out in accordance with the relevant requirements of:

- The appropriate Building Regulations either The Building Regulations, The Building Regulations (Scotland) or Building Regulations (Northern Ireland).
- The Water Fittings Regulations or Water Byelaws in Scotland.

WARNING: IF WATER FLOWS FROM THE PRESSURE RELIEF VALVE, THE ELECTRICITY SUPPLY MUST BE SWITCHED OFF IMMEDIATELY. CONTACT A COMPETENT INSTALLER FOR UNVENTED WATER HEATERS TO CHECK THE SYSTEM.

FIGURE 02: For inlet pressures up to 0.41MPa (4.1 bar)

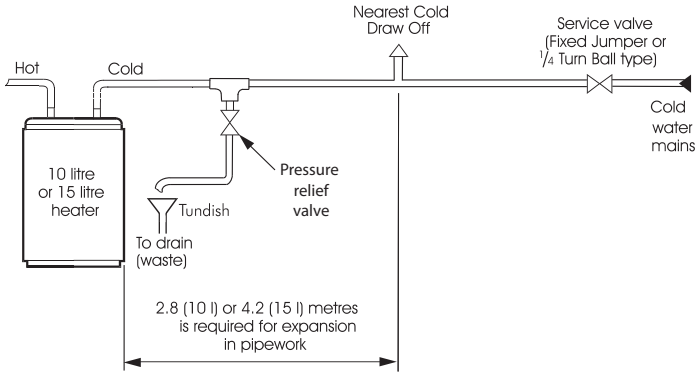

FIGURE 03: For inlet pressures up to 0.41 MPa (4.1 bar) where expansion in mains supply is not possible.

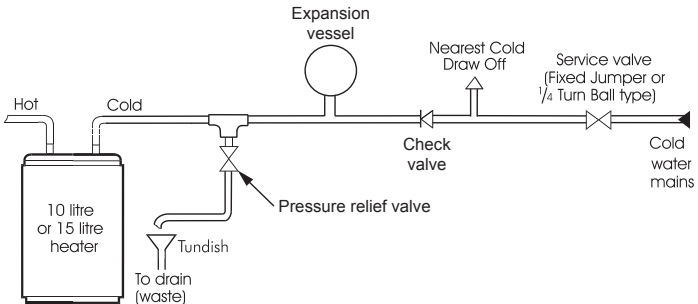
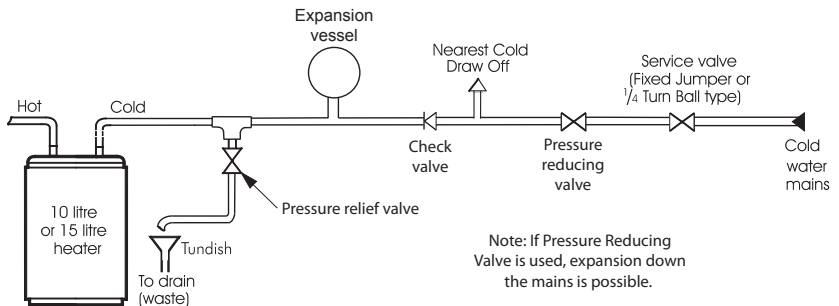

FIGURE 04: For inlet pressures above 0.41 MPa (4.1 bar)



3.4 DISCHARGE

- 3.4.1 The discharge outlet from the Pressure (expansion) Relief Valve must be connected to a discharge pipe. It is recommended that a tundish be installed in the discharge pipe to give a visible indication that the valves are operating.
- 3.4.2 The discharge pipe must fall continuously from the valve outlets and be unobstructed and in a frost-free environment.
- 3.4.3 The pipe from the valves to the tundish should be 15mm o/dia minimum. From the tundish to the point of discharge the pipe should be 22mm o/dia minimum and have a resistance to flow equivalent to 9 metres of straight pipe. Long discharge pipe runs should have an increased internal diameter.
- 3.4.4 The water may drip from the discharge pipe of the pressure relief device and this pipe must be left open to the atmosphere. The pressure relief device is to be operated regularly to remove lime scale deposits and to verify that it is not blocked.
- 3.4.5 The pipe material should be capable of conveying water/steam at 100°C.
- 3.4.6 The final discharge point should be in a safe, visible position.

3.5 ELECTRICAL

WARNING: This appliance must be earthed. It is suitable for a.c. supply only. Disconnect the electrical supply before removing the terminal cover. Installation must be in accordance with the current I.E.E. Wiring Regulations.

3.5.1 The unit is supplied fitted with a 0.75m 3 core 1mm² flexible cable. The electricity supply should be fused 13 Amp and be via a double pole isolating switch with a contact separation of at least 3mm in both poles. Refer to the schematic wiring diagram Figure 05 below.

3.5.2 The wires are colour coded as follows:

Green and Yellow	EARTH	
Brown	LIVE	(L)
Blue	NEUTRAL	(N)

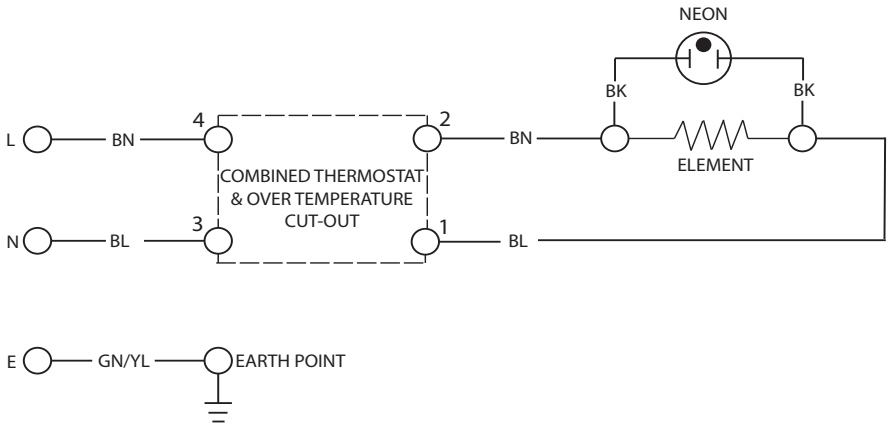

FIGURE 05: WIRING DIAGRAM

4.0 COMMISSIONING

4.1 PLUMBING

- 4.1.1 Do not switch on the electrical supply until the unit has been filled with water and checked for leaks.
- 4.1.2 Check that all installation, electrical and discharge pipe requirements have been met.
- 4.1.3 Check that all water and electrical connections are tight.
- 4.1.4 Open a hot water tap, turn on mains water supply to the heater.
- 4.1.5 Allow unit to fill and leave hot tap running for a short while to purge any air and flush out the pipework. Close the hot tap and check the system for leaks.
- 4.1.6 Manually test the operation of the Pressure (expansion) Relief Valve. Ensure water flows freely from the valve and through the discharge pipes.

4.2 ELECTRICAL

- 4.2.1 Switch on the electrical supply. The indicator light will illuminate during heating. When the set temperature is reached, the indicator light will go out.
- 4.2.2 The set temperature can be adjusted by rotating the knob on the front face of the unit. Rotate clockwise to increase temperature, anti-clockwise to reduce temperature. Setting 2 on the temperature control knob equates to a water temperature of approx 45°C.
- 4.2.3 Water may drip from the discharge pipe of the pressure relief device - this pipe must be left open to atmosphere.

5.0 EXPLANATION TO USER

Following Installation and Commissioning of the water heater, the operation should be fully explained to the user.

5.1 HOT WATER

- 5.1.1 Indicate the location of the water heater and identify the outlets to which it is connected.
- 5.1.2 Explain that the temperature is set upon installation and confirm the temperature which the water is set at.

5.2 SYSTEM MALFUNCTION

- 5.2.1 Explain how to isolate electrical and water supplies in case of a fault.
- 5.2.2 Explain that a qualified plumber and/or electrician should be contacted if there is a fault.
- 5.2.3 Explain how to identify/check basic faults (Section 7.0).

5.3 SYSTEM MAINTENANCE

- 5.3.1 Explain the necessity to carry out regular maintenance of the water heater to ensure its continued safe and efficient operation.

5.4 LITERATURE

- 5.4.1 Hand over the Installation and user instructions.

5.5 IMPORTANT NOTES TO USER

- 5.5.1 This unvented heater stores water at the temperature set on the adjustable thermostat. This can be set to give temperatures in the range of 12 to 72°C. To avoid any risk of freezing when the heater is not in use for long periods during the winter months, do not switch off the electrical supply and set the thermostat to its minimum position. N.b. This will not protect other system pipework.
- 5.5.2 The indicator light will only be illuminated when the unit is heating.
- 5.5.3 Do not block or restrict the discharge from any safety valve fitted.
- 5.5.4 Do not tamper with any safety valve fitted.
- 5.5.5 If water discharges from any safety valve fitted, switch off the electrical supply to the unit immediately. Do not turn the electrical supply on again until the unit has been checked and approved by a qualified installer.

6.0 MAINTENANCE

Warning: disconnect from all electrical supplies before beginning any work on the unit. Water contained within the unit may be very hot!

Maintenance should be carried out by a competent person and any replacement parts should be authorised Supplier spare parts.

It is recommended that maintenance is carried out regularly and should include the checks detailed in the sections below.

- 6.1 Little maintenance is required, however in hard water areas the unit will require descaling approximately every two years to ensure efficient operation. The magnesium anode should be replaced every two years.

To carry out this operation:

- 6.1.1 Switch off and disconnect the electrical supply. Turn off the water supply to the unit.
- 6.1.2 Open a hot tap to relieve any system pressure. Disconnect the plumbing connections to the unit and remove from the wall (note full weights of units in Section 2). Empty unit by tipping through 90° over a sink.
- 6.1.3 Remove the top cover by removing the two recessed self-tapping screws on the top of the unit.
- 6.1.4 Prise off the front temperature control knob which is attached to the thermostat spindle.
- 6.1.5 The top cover can now be removed by lifting vertically.
- 6.1.6 Carefully remove retaining plug and both capillary sensors from the hole in the circular element plate but avoid kinking or straining the capillary tubes.
- 6.1.7 Remove the earth wire from the element plate.
- 6.1.8 Remove the element plate assembly by removing the four securing nuts. Remove any loose scale from the container. Carefully clean off any scale from the element and thermostat pocket. DO NOT clean scale from interior container walls.
- 6.1.9 To replace the magnesium anode, unscrew from the element assembly. Fit the new anode as a reversal of this procedure.
- 6.1.10 Refit the element plate assembly, fitting a new sealing gasket if required. Note the correct orientation of the element plate by reference to Figure 06, page 12. Refit the capillary sensors, retaining plug and earth wire. Refit the cover, insert the two self-tapping screws to secure and refit the temperature control knob.

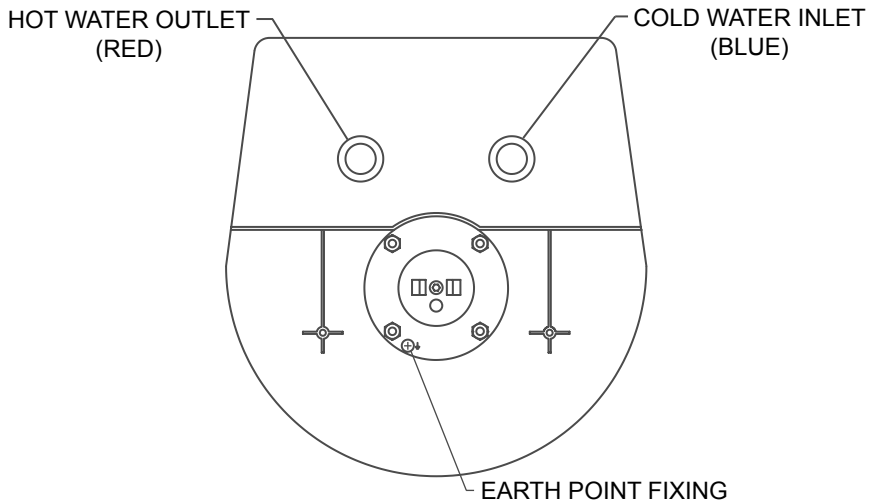

FIGURE 06: CORRECT ORIENTATION OF ELEMENT PLATE
(VIEWED FROM TOP WITH COVER REMOVED)

- 6.1.11 Re-commission the unit following the INSTALLATION and COMMISSIONING instructions.
The Pressure (expansion) Relief Valve should be regularly checked. This is to remove limescale deposits and to verify that it is not blocked. To check the valve:
- 6.1.12 Manually operate the valve by twisting the cap. Ensure water flows freely from the valve and through the discharge pipes. Ensure the valve re-seats correctly when released.
The Expansion Vessel, if fitted, should have a pre-charge pressure of 0.41 MPa (4.1 bar). This can reduce over time and eventually require re-charging. To do this:
- 6.1.13 Turn off water supply to the unit; open a hot tap to relieve system pressure.
- 6.1.14 Remove dust cap from top of Expansion Vessel
- 6.1.15 Check pre-charge pressure using a tyre pressure gauge. If the pressure is lower than 0.41 MPa (4.1 bar) it should be recharged using a tyre pump (Schraeder Valve type). **DO NOT OVER CHARGE.**
- 6.1.16 Re-check pressure and when correct replace dust cap.
- 6.1.17 Turn on mains water supply and close hot tap.

7.0 FAULT FINDING

Disconnect the electrical supply before removing the terminal cover. It is recommended that any service operations on the heater are carried out by a competent person.

FAULT	POSSIBLE CAUSES	ACTION
Water not heating	1. Electrical supply fault	Check electrical supply
	2. Thermal cut-out tripped	Check cut-out, if operated, reset and check thermostat operation. If necessary replace thermostat/thermal cut-out (see Wiring Diagram Fig.05, page 8)
	3. Thermostat fault	Check thermostat operation. Replace if necessary.
Discharge of water from pressure relief valve	Excessive mains water pressure	Fit Expansion vessel, check valve and pressure reducing valve.
Discharge of water from pressure relief valve (intermittently).	1. Expansion in mains not possible.	Fit Expansion vessel and check valve (see IMPORTANT INSTALLATION POINTS SECTION 3)
	2. Mains pressure exceeds 0.41 Mpa (4.1 bar)	Fit Expansion vessel, check valve and pressure reducing valve.
	3. Pressure Relief Valve Fault	Replace Pressure Relief Valve
	4. Loss of pressure from Expansion Vessel	Check and, if necessary, re-charge Expansion Vessel pre-charge pressure (see section 6.1.12)
Discharge of water from Temperature/Pressure relief valve and/or water/steam from pressure relief valve	Thermostat and thermal cut out fault	Replace thermostats and thermal cut outs
No water flow	1. Inlet valves incorrectly fitted	Check all valves are correctly installed in accordance with flow direction arrows
	2. Mains water supply not turned on	Check mains water supply is on
	3. Blockage in main water supply	Check for obstructions. If pressure reducing valve with strainer is fitted, check strainer is not blocked
"Milky water"	Oxygenated water	Water from a pressurised system releases oxygen bubbles when flowing. The milkiness will disappear after a short while

8.0 SPARE PARTS

The following list of spare parts is available for your water heater. Please refer to the Rating Label on the top of your heater before ordering to ensure the correct spare part is obtained.

DO NOT REPLACE WITH PARTS NOT RECOMMENDED BY THE MANUFACTURER - THIS WILL INVALIDATE YOUR GUARANTEE AND MAY RENDER THE INSTALLATION DANGEROUS.

DESCRIPTION	CODE NO.
Element assembly 2kW	95606906
Magnesium anode (10/15l)	95607957
Thermostat/over temp cut-out	95612718
Pressure relief valve	95605896
Temperature control knob	95605895
Element plate gasket	95611022
Neon	95607942

9.0 GUARANTEE

This water heater is guaranteed for parts only for a period of one year from the date of purchase provided:

1. The unit has been installed in accordance with these instructions.
2. The unit has not been tampered with and has been regularly maintained as detailed in these instructions.
3. The unit has been used only for heating potable water.

The unit is not guaranteed against damage by frost and the inner container with integral immersion heater is not guaranteed against excessive scale build up.

This guarantee does not affect the statutory rights of the consumer.

Please attach proof of purchase to all correspondence relating to warranty claims.

10.0 ENVIRONMENTAL INFORMATION

This product is manufactured from many recyclable materials. At the end of its useful life it should be disposed of at a Local Authority Recycling Centre to realise the full environmental benefits.

11.0 WARRANTY & SPARE PARTS ENQUIRIES

Hydrocare
Brooks House
Coventry Road
WARWICK
CV34 4LL
Tel: 0844 871 1532

The policy of Hydrocare is one of continuous product development and as such, we reserve the right to change specification without notice.